

## **Identification of obstacles ahead of tunnel face applying inverse approach**

**Jörg Meier<sup>1</sup>, Maria Datcheva<sup>2</sup> and Tom Schanz<sup>3</sup>**

<sup>1</sup>Gruner AG, Basel, Switzerland

<sup>2</sup>Institute of Mechanics, Bulgarian Academy of Sciences, Sofia, Bulgaria

<sup>3</sup>Laboratory of Foundation Engineering, Soil and Rock Mechanics, Ruhr University Bochum, Germany

### **Abstract**

One of the major challenges in tunnelling is the assessment of the location and properties of large stiff or weak zones ahead of the tunnel face. In this paper a concept is presented, how numerical modelling in conjunction with displacement measurements at the tunnel lining over construction stages can be used for identification of geometrical and constitutive parameters of a hard rock inclusion in front of the tunnel face. The size of the inclusion, its position and material parameters are determined by back analysis. The obtained results show that a robust in nonlinear applications optimization algorithm such as the Particle Swarm Optimisation (PSO) is an efficient tool for geometric and material model parameter identification based on measurements during the tunnel construction. The concrete application reported here concerns the determination of the size and position of a stiff rock inclusion ahead of the tunnel advance. The prospective of using PSO in solving specific tasks related to tunnelling is also discussed.

**Keywords:** Back-analysis, Optimization, Numerical Modelling, Particle Swarm Approach

## **1 INTRODUCTION**

Tunnelling is part of the human construction practice for more than 2000 years, in particular playing important role in building up of road and railway infrastructure. Since the last few decades there is an evident increase in tunnel construction projects, especially in municipal and mountain areas. Due to the strict requirements for planning and construction these projects are usually complex and expensive. Numerical modelling is well accepted method for assisting in proper planning and in efficient tunnel excavation processing. It is out of the scope here to give literature review on numerical modelling in tunnelling but one can refer to e.g. ECCOMAS thematic conference EURO:TUN 2007 and also to these proceedings for various examples of numerical applications. Our attention is on the identification of the model parameters which is of paramount importance in numerical simulations because reducing the uncertainty in model parameters we increase our confidence in the numerical predictions. Values for model parameters can be obtained by performing field measurements or from laboratory tests. In tunnelling however it is often technically difficult to collect sufficient data for direct model identification. Instead by back analysis we can significantly improve the accuracy of the numerical model and thus to guarantee more reliable predictions. That is why there has been a growing interest in application to geotechnical modelling of inverse parameter identification strategies. An overview and extensive list of references may be found in [3].

Even for modern tunnelling techniques large stiff-material obstacles and fault zones are difficult issues as they can influence the financial, technical and overall cost of the project. Inverse determination of geometrical and material characteristics of a weak zone in front of the tunnelling is reported in [5]. The example presented in this paper demonstrates in terms of numerical experiment and direct back analysis the determination of the location, the size and some material parameters of a stiff rock inclusion ahead the tunnelling advance.

## **2 THEORETICAL BACKGROUND**

Back analysis problems may be solved in two different ways, defined as inverse and direct approaches. The inverse back analysis consists in inverting the model equation with respect to the parameters that are unknown and subject to identification. The direct approach is based on an iterative procedure correcting the trial values of the unknown parameters by minimizing error functions. This way the model response

data are provided by trial forward solutions of the problem used for model parameters identification. For the analysis presented here the iterative direct approach has been chosen. **Figure 1** shows the flowchart of the direct approach to the back analysis. The iterative approach consists in choosing an objective function  $f(x_1, x_2, \dots, x_n)$  with  $n$  unknown model parameters that measures the agreement between the available data and the solution of the forward calculation. Starting with an initial guess for the parameters the optimization algorithm calls the forward solver once or several times and extracts the relevant data from the solution of the forward problem to figure the objective function. The procedure continues up to finding the set of parameters that minimizes the objective function.

The proper choice of the method for solution of the objective function minimization problem is of a paramount importance for the efficiency and robustness of the back analysis. Over the past decade a number of optimization algorithms have been used extensively in optimization tasks, starting with gradient-based algorithms using continuous and in most cases convex objective functions, ending to non-gradient probabilistic-based search algorithms widely applied for global and non-convex design exploration. From this latter category of algorithms we use here the PSO. There is a vast literature concerning PSO. Short description of the PSO can be found elsewhere, e.g. in [2] and particularly its application to geotechnical problems is discussed in [3, 4, 5, 6, 7].

### 3 BACK ANALYSIS OF A STIFF ROCK MASS IN FRONT OF TUNNELLING

This section presents an application of the inverse technique for locating and identifying a stiff contiguous rock block in front of a tunnel advancing in soft rocks.

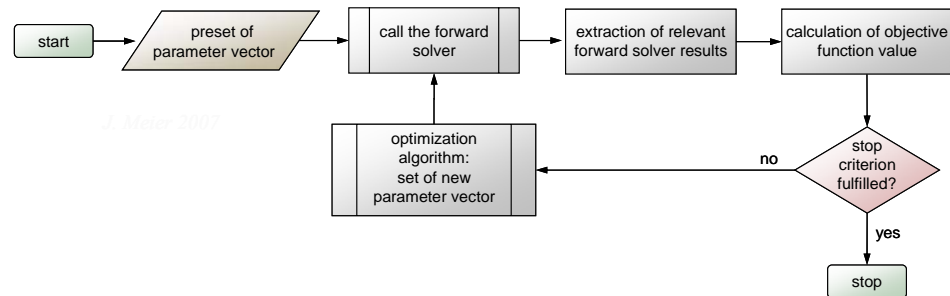

**Figure 1:** Flowchart of the adopted iterative procedure

The stiffness, size and location of this contiguous stiff rock-block are back calculated based on a 3D numerical model and measured displacements at 4 point of the tunnel face contour. We perform a numerical experiment for gaining synthetic reference data. Next the same numerical model is used for the forward calculation in the inverse model parameter determination procedure. The main advantage is that the solution of the inverse problem in form of the “correct” parameter combination is known and thus the present example can be used for validation of the back-analysis procedure.

### 3.1 Statement of the problem

**Figure 2** shows the scheme of the model setup used in this example. The overall size of the model is 200 x 200 x 500 m. The top-surface of the model is assumed to correspond to the ground surface. With the exception of the upper face, all outer surfaces are fixed normal to their extension and this way the "clamping" in the surrounding material is simulated. The height of the rock mass above the tunnel is 110 m and the tunnel is modelled as a cylindrical hole with cross section of 20 m. The gravity force is applied in the vertical direction (coordinate 3 in **Figure 2**). The tunnelling process is modelled by 27 excavation steps with an excavation advancing of 10 m. The problem is solved taking into account geometrical non-linearity and as forward solver the general purpose finite element method (FEM) code ABAQUS, [1] is used. The rock mass surrounding the tunnel is supposed to be composed of a cohesionless material and its behaviour is described by the Modified Cam-Clay material model from the ABAQUS/Standard, [1] material library. **Table 1** gives the material parameters used for the numerical experiment. The material model for the stiff rock inclusion is the linear elastic model.

For the inverse determination of the rock-block position and size, the numerical model must be updated in correspondence to the variation of the geometrical characteristics of the stiff-rock inclusion. We utilize for this a mesh deformation strategy that adapts the FE mesh to the current model geometrical parameters of the stiff-rock block by a transformation of node coordinates. Thus all forward calculations are done having the same number of FE nodes and elements. It is only the shape of the finite elements that changes with changing the geometry of the stiff-rock block. The model is discretised by 26,438 tetrahedral finite elements.

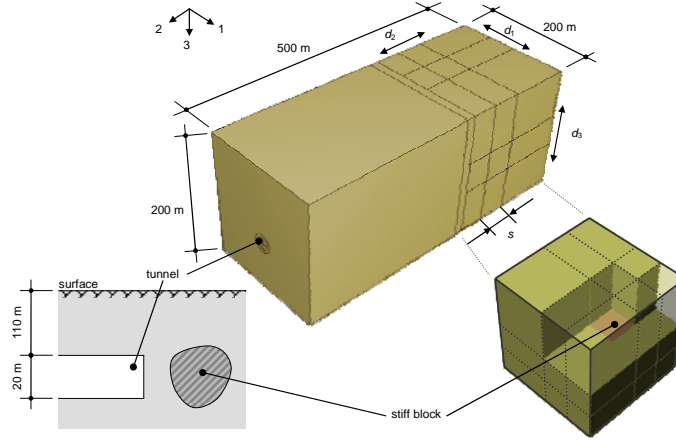

**Figure 2:** Scheme of the model setup

In two successive calculation steps the geostatic stress state is applied and the equilibrium state is achieved. In the 27 consequent idealised excavation steps the tunnelling is simulated by removing the given parts from the model. For each calculation step, the construction stage-displacement behaviour of the tunnel crown, the tunnel bottom and the left and right walls is recorded. Completing all the 27 steps of the tunnelling advance simulation we have 4 data series consisting of 27 members, or total data series length is 108.

The parameters to be determined are  $d_1$ ,  $d_2$  and  $d_3$  defining the position of the stiff-rock block in the three-dimensional space, the characteristic size of the block  $s$  adopted in all spatial dimensions the same size, see **Figure 2**, and the stiffness characteristic, the compression (rebound) index  $\kappa$  of the soft-rock material surrounding the stiff-rock block.

The reference displacement data set is collected from the forward solution where  $d_1 = 7.0$  m,  $d_2 = -16.0$  m,  $d_3 = -7.0$  m,  $s = 34$  m and  $\kappa = 5.6E-09$ .

**Table 1:** Parameter values of the surrounding rock mass

Parameter	Value	Parameter	Value
plastic compression index $\lambda$	0.4	density $\rho$	2200 kg/m <sup>3</sup>
slope of the critical state line $M$	0.2	Poisson's ratio $\nu$	0.3
initial size of the yield surface $a_0$	1.5E+06 Pa	compression (rebound) index $\kappa$	0.1
elliptic-cap parameter $\beta$	1	tensile strength $p_t$	0 Pa
shape parameter of yield surface $K$	1		

### 3.2 Parameter back calculation

Because reference data as well as simulation results are composed only of time-displacement series of individual measurement points the available data are of the same physical type and similar in magnitude. Therefore for definition of the objective function the sum of the mean square deviations can be used and it reads:

$$f(x) = \frac{1}{4} \sum_{j=1}^4 [f_j(x)] \quad \text{with} \quad f_j(x) = \frac{1}{27} \sum_{h=1}^{27} \left[ (u_{h,j}^{calc}(x) - u_{h,j}^{meas})^2 \right] \quad (1)$$

At tunnel side walls  $u_h$  is the horizontal component of displacement and at tunnel crown and bottom it equals to the vertical component of the displacement vector. The vector of unknown parameters is  $x = \{d_1, d_2, d_3, s, \kappa\}$ .

Statistical analysis via matrix plot is performed based on Monte Carlo sampling method (for details see [6]). This analysis shows that all parameters in  $x$  influence the simulation results, with respect to each of the unknown parameters the objective function has well defined optimum and there are no correlated parameters.

For solving the optimization problem we apply the PSO technique. The sequence diagrams of the PSO are depicted in **Figure 3**. These diagrams indicate, that the optimization algorithm converges relatively fast in a local optimum where the objective function value is  $f(x) = 1.8903E-10$ . With respect to the jumps found in the objective-function topology by the statistical analysis it can be stated, that the algorithm was “stuck” to these fluctuations until the loop 42 of the series. Especially in the range from loop 37 to loop 40 there is an indication of increasing of the number of forward calculations which fail and the numerical solution becomes instable. Based on these observations, for loop 43 the weighting factor controlling the stochastic part in the PSO-particle-vector determination procedure was amplified. Consequently, within loop 43 a parameter set that gives a smaller value of the objective function was found and thus the search activity of the swarm was reanimated. The next loops show a relative large range of objective function value variation. This result indicates an existence of further jumps and distinct roughness of the objective function topology. It has been observed that the optimization algorithm improves within 100 executed loops (1000 forward calculation calls). The parameter set corresponding to  $f(x) = 5.55E-12$  can be found in **Table 2**.

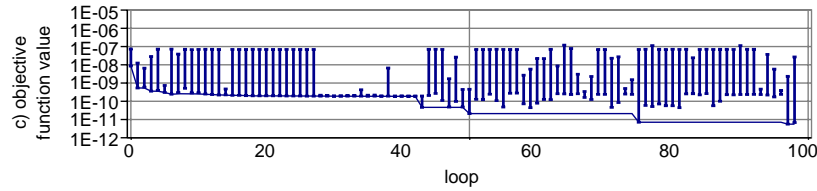

**Figure 3:** Sequence-Diagram for the PSO method

This example of parameter values back-calculation of a stiff-rock block in front of tunnel advancing reveals several problems that may rise in inverse model parameter identification for geotechnical tasks. In addition to the numerical instabilities and too many failed forward calculations, the objective-function topology roughness it has to be pointed the comparatively lasting forward calculations - about 15 to 25 minutes per execution on a PC with a clock frequency of 3 GHz and 2 GB of RAM. However despite these difficulties it is possible to get good estimate to the reference “correct” parameter set.

#### 4 CONCLUSIONS

This paper presents a 3D direct back-analysis for identifying inclusions ahead of tunnel advancing. The inverse analysis is based on displacement data measured at the tunnel face during tunnel advance, least square regression technique, correlation analysis via matrix plots and application of PSO algorithm. The capability of the proposed procedure has been demonstrated and discussed on an example for estimating, considering synthetic data, constitutive characteristic of the surrounding rock and geometrical model parameters of stiff-rock block ahead of tunnel advancing in soft rock. The present study provides complementary results to the reported in [5] back analysis of weak-rock zone ahead of the tunnel advance. The main outcome is that 3D back-analysis offers a promising tool for gaining information on both material and geometrical features in different geotechnical projects related to tunnelling. For performing the proposed direct back analysis procedure the general purpose finite element code ABAQUS has been linked to a self developed optimization tool. The

**Table 2:** Overview of the results of the different optimization sequences

	$f(x)$	$d_1$ (m)	$d_2$ (m)	$d_3$ (m)	$s$ (m)	$\kappa$ (-)
reference parameter set	n/a	7.000	-16.000	-7.000	34.00	5.600E-09
PSO result	5.55E-12	6.933	-15.931	-7.136	34.02	5.834E-09

obtained results yield to the conclusion that with the use of the PSO algorithm a successful back analysis of the unknown parameters may be done with acceptable number of forward calculation runs in spite of numerical instabilities and non-smooth objective surface. Next step should be the application of the proposed approach to real field situations.

## REFERENCES

- [1] ABAQUS User Manual, Abaqus Inc., Version 6.5-1.
- [2] R. C. Eberhart and J. Kennedy. A new optimizer using particle swarm theory. In *Proceedings of the 6th International Symposium on Micro Machine and Human Science (MHS '95)*, Nagoya, Japan, pages 39–43, 1995.
- [3] J. Meier. Parameterbestimmung mittels inverser Verfahren für geotechnische Problemstellungen. *Dissertation*, Verlag der Bauhaus-Universität Weimar, Schriftenreihe Geotechnik, Heft 19, 2008.
- [4] J. Meier, S. Rudolph and T. Schanz. Effektiver Algorithmus zur Lösung von inversen Aufgabenstellungen-Anwendung in der Geomechanik. *Bautechnik*, 83(7):470 – 481, 2006. Ernst & Sohn, Berlin.
- [5] J. Meier, M. Datcheva and T. Schanz. Identification of constitutive and geometrical parameters of numerical model with application in tunnelling. In *Proc. ECCOMAS Thematic Conference EURO:TUN 2007*, J. Eberhardsteiner et.al. (eds.), CD edition. 2007.
- [6] J. Meier, W. Schädler, L. Borgatti, A. Corsini and T. Schanz. Inverse Parameter Identification Technique using PSO Algorithm Applied to Geotechnical Modeling. *Journal of Artificial Evolution and Applications*, doi:10.1155/2008/574613, 2008.
- [7] T. Schanz, M.M. Zimmerer, M. Datcheva and J. Meier. Identification of Constitutive Parameters for Numerical Models via Inverse Approach. *Felsbau*, 24(2):11 – 21, 2006.